

UNICAST REDEFINING WEAR PARTS

Ceramic Lined Diverter Valves



AGGREGATES



MINING



CEMENT

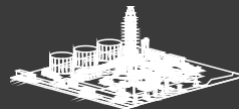

OIL & GAS



COAL

Unicast designs and distributes world-leading, high-quality wear parts for the aggregates, mining, cement, oil and gas, and coal industries.

📍 1200 MAYFAIR RD. KELOWNA, BC CANADA V1X 7W7 📞 250-807-7999 ✉ WEARPARTS@UNICAST.CA 🖱 UNICAST.CA

Unicast sells to customers and distributors worldwide.

Unicast Global Offices



We are based in Western Canada with representatives in Eastern Canada, USA, Latin America, Europe, and Asia.

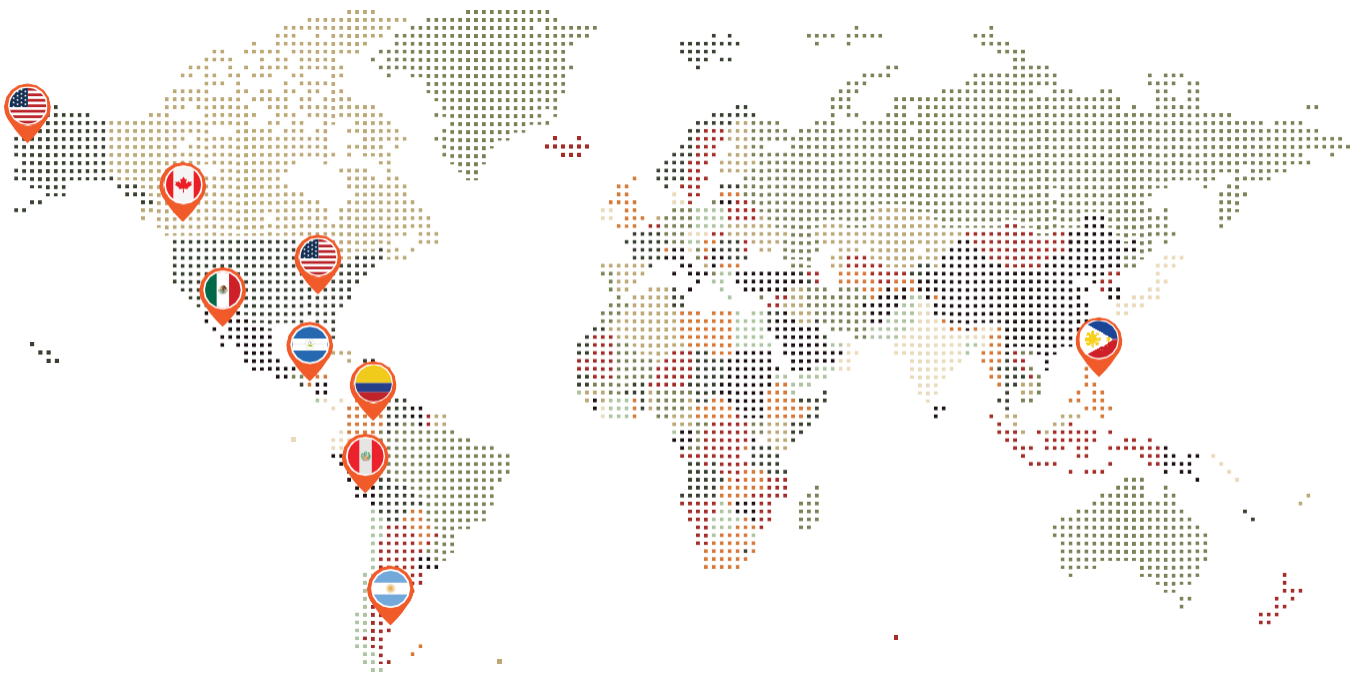

World-leading & high-quality wear parts.

About Unicast

∞ *The world's longest lasting wear parts.*

For 30 years, Unicast's mission has remained the same: **To respond to industrial wear part challenges and deliver innovative wear parts with outstanding wear life.**

Extreme temperatures, high-impact work, and tough materials wreak havoc on wear parts. The frequent replacement and maintenance of these parts waste huge amounts of time and money. Unicast helps cut down on costs and makes maintenance staff's job easy by providing wear parts that can withstand even the most abrasive conditions and materials.

Unicast wear parts last longer than other products on the market and are easy to install and maintain. This minimizes downtime while maximizing operations' profitability.

Founded in 1994, Unicast is a subsidiary of Decisive Dividend Corporation, a growing and publicly traded company on the TSX Venture Exchange under the symbol 'DE'.

Unicast sells to distributors, process plants, and mine sites worldwide. Based in Kelowna, British Columbia, Unicast works across multiple continents in the mining, cement, oil, gas, aggregates, and coal industries.



Capabilities



OEM REPLACEMENT CASTINGS

Our capabilities range from investment castings a few grams in weight to sand castings weighing several tonnes.



QUALITY CONTROL

Unicast prides itself on its rigorous quality control procedures such as partner foundry reports, materials characterization, and much more!



METALLURGY

We offer multiple cutting-edge, secondary materials that enhance the durability and quality of products.



FOUNDRIES

Unicast products are engineered by our dedicated team of in-house engineers in British Columbia and manufactured by our partner network of global foundries.

Industry Leading 25 Year Warranty

EASY INLINE MAINTENANCE MINIMAL DOWNTIME

The Unicast two-way Diverter Valve sets the standard for inline maintenance and durability. Single-handedly perform routine in-line maintenance in 4 hours or less. No crane. No hoist. No lift. No stress. Just awe and respect as you get your plant up and running again in record breaking time.

Slash massive down-for-the-day maintenance costs to dramatically improve your plant's bottom line!



WHY CHOOSE UNICAST FOR YOUR VALVE REQUIREMENTS?

- **25 Year Warranty:** Unicast is proud to state that we have the best valves in the industry. We back this up by offering a 25-year warranty on our valve bodies and ceramic liners. These bad boys are Cast to Last!
- **Quick Turnaround!** Our average lead time on our best-selling sizes (6", 8", 10", 12", 14") is 2 to 4 weeks. Custom valve sizes up to 24" can be made to order.
- **Expert Technical Assistance:** Unicast offers support options including but not limited to maintenance assistance, refurbishment and upgrade of older Unicast valves, and on-site technical training!
- **Split-Modular Valve:** This newer, sleeker design is made to fit in spots with minimal clearance. It also facilitates easier and faster switching of Right-Left orientation convertibility. Available in sizes from 8" and upwards.
- **30° and 45° Angled Outlets Available:** Endless configurations for maximum flexibility and adaptability. 30-degree valve available in 6", 8" and 10". Ask us about custom sizes!
- **Ceramic Liners:** High-wear areas lined with 13mm (1/2") thick cast ceramic liners are backed with an industry leading 25-year warranty.
- **Right-Left Convertibility:** Designed with a shaft hole on either side of the valve for quick and easy reconfiguration. One valve, two directions.



SMW Diverter Valve (Motorized)

OTHER FEATURES



Large Access Panel: Quick and easy inline maintenance. Easily replace wearing parts, such as the gate and seat, without a crane, hoist, or lift with less downtime.

One-Piece Seat: Precision alignment between the gate and seat for a perfect seal. Simple one-man in-line gate and seat maintenance. Save Manpower, Downtime and Money.

Multiple Options: Unicast Valves are available in Motorized, Pneumatic and Manual actuation options.

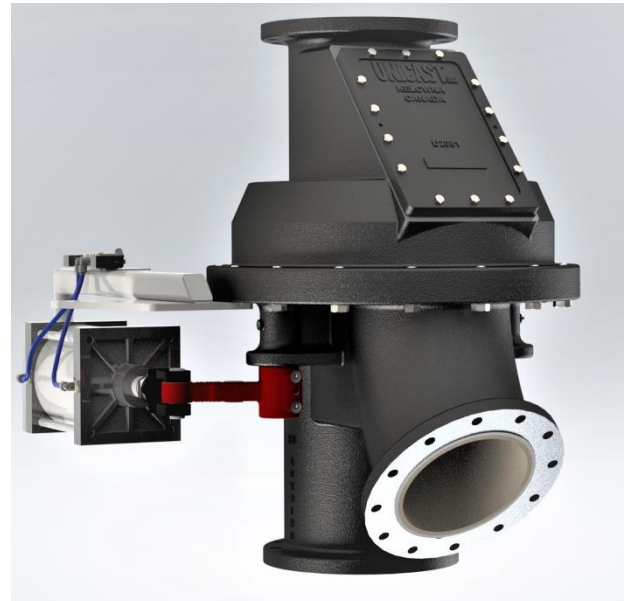

Classic Diverter Valve (Pneumatic)

UNICAST



SMV Diverter Valve Maintenance Manual

QR code on Every Valve: Each Unicast valve comes with a QR code that accesses a comprehensive maintenance manual for your staff.

←SCAN to access valve maintenance manual

NEW FEATURES

← **Direct Drive Motorized Actuation Option:**

Minimal Linkages: Motor assemblies directly to the shaft.

120V AC Power: No need for step-up transformers

Built in Limit Switches: Accurate feedback to PLC control room.

Built in Handwheel: Manually move the gate's position.

Handwheels for Manually actuated Valves→

Optional add-on or upgrade to enable easier gate position change.

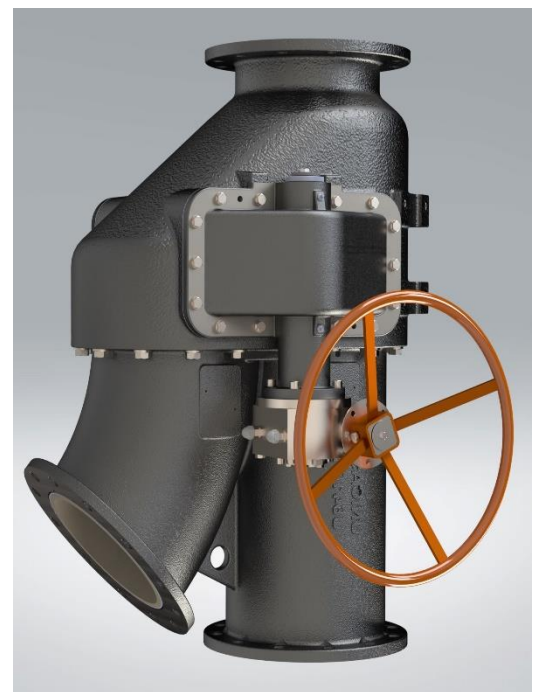

ADDITIONAL VALVE OFFERINGS

Unicast offers **Shutoff Valves, Ball-check Valves (UniBall), Double Gate, and Ceramic-Lined Pipes and Elbows** for material transport as well.



Shutoff Valve. Motorized

Shutoff Valves

One-piece high chrome iron seats and liners: Provides total protection in abrasive environments installed on both inlet and outlet sides.

Standard flange-to-flange dimensions: Compact design fits into the same flange spacing as other popular brands, making the switch to Unicast Shut-Off Valves easy.

Multiple Actuation options available: Pneumatic Actuator and Electric gear motor actuator with limit switches.



Uniball

UniBall Valve (Ball Check Valve)

Easy to remove Access Doors (on both sides): Perform hassle-free maintenance on the UniBall Valve without removing it from the pipeline. Save money and time!

Built to Last: The housing is cast in one-piece using the Unicast proprietary alloy D1 for durability. Rubber coating on the housing, steel ball, and seats shield the valve and its parts from abrasive slurry.

Ceramic Lined Elbows and Pipes

Standard pipe flanges: Designed to match standard pipe flanges for easy installation in high-wear areas of the pipeline only. Customizable for any size.

Silicon Carbide Lining: Silicon Carbide ceramic lined is used to provide high resistance to abrasion. Thickness of lining can be adjusted as needed.



←SCAN to access Unicast's valve video



Ceramic Lined Elbow

CLASSIC DIVERTER VALVE DIMENSIONS DATA SHEET

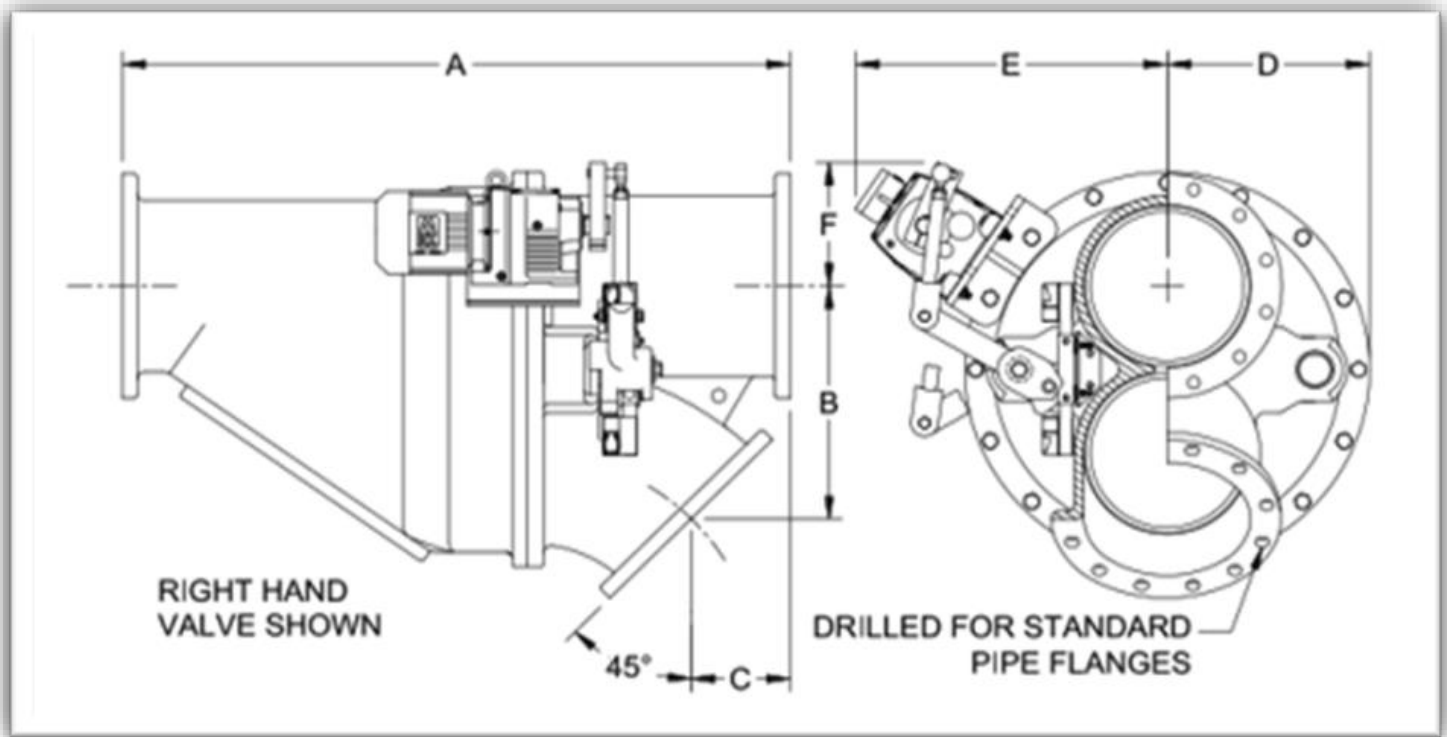

| PART NUMBER | SIZE | A | B | C | D | E | F | WEIGHT |
|-------------|-------|--------|--------|-------|--------|--------|--------|----------|
| U2501 | 4" | 24.00" | 8.31" | 3.43" | 8.00" | 11.07" | 10.88" | 550 Lbs |
| | 102mm | 610mm | 211mm | 87mm | 203mm | 281mm | 276mm | 250 Kg |
| U2751 | 5" | 27.87" | 11.00" | 4.27" | 8.62" | 12.43" | 9.36" | 590 Lbs |
| | 127mm | 708mm | 279mm | 109mm | 219mm | 316mm | 238mm | 268 Kg |
| U2401 | 6" | 29.00" | 10.75" | 5.25" | 10.00" | 17.31" | 9.09" | 627 Lbs |
| | 152mm | 737mm | 273mm | 133mm | 254mm | 440mm | 23mm | 285 Kg |
| U2301 | 8" | 36.00" | 13.70" | 5.25" | 12.50" | 20.33" | 10.25" | 784 Lbs |
| | 203mm | 914mm | 348mm | 133mm | 318mm | 516mm | 260mm | 340 Kg |
| U2081 | 10" | 40.00" | 17.00" | 7.12" | 14.75" | 22.18" | 12.49" | 1078 Lbs |
| | 254mm | 1016mm | 432mm | 181mm | 375mm | 563mm | 317mm | 490 Lg |
| U2051 | 12" | 46.00" | 18.62" | 7.00" | 16.75" | 24.00" | 10.60" | 1375 Lbs |
| | 305mm | 1168mm | 437mm | 178mm | 425mm | 610mm | 269mm | 625 Kg |
| U2351 | 14" | 61.00" | 21.81" | 9.00" | 18.50" | 28.78" | 12.31" | 2387 Lbs |
| | 356mm | 1549mm | 554mm | 229mm | 470mm | 731mm | 313mm | 1085 Kg |
| U2801 | 16" | 62.50" | 24.25" | 8.50" | 21.00" | 34" | 12.50" | 2860 Lbs |
| | 406mm | 1588mm | 616mm | 216mm | 533mm | 864mm | 318mm | 1300 Kg |

SPLIT MODULAR VALVE DIVERTER VALVE DIMENSIONS DATA SHEET

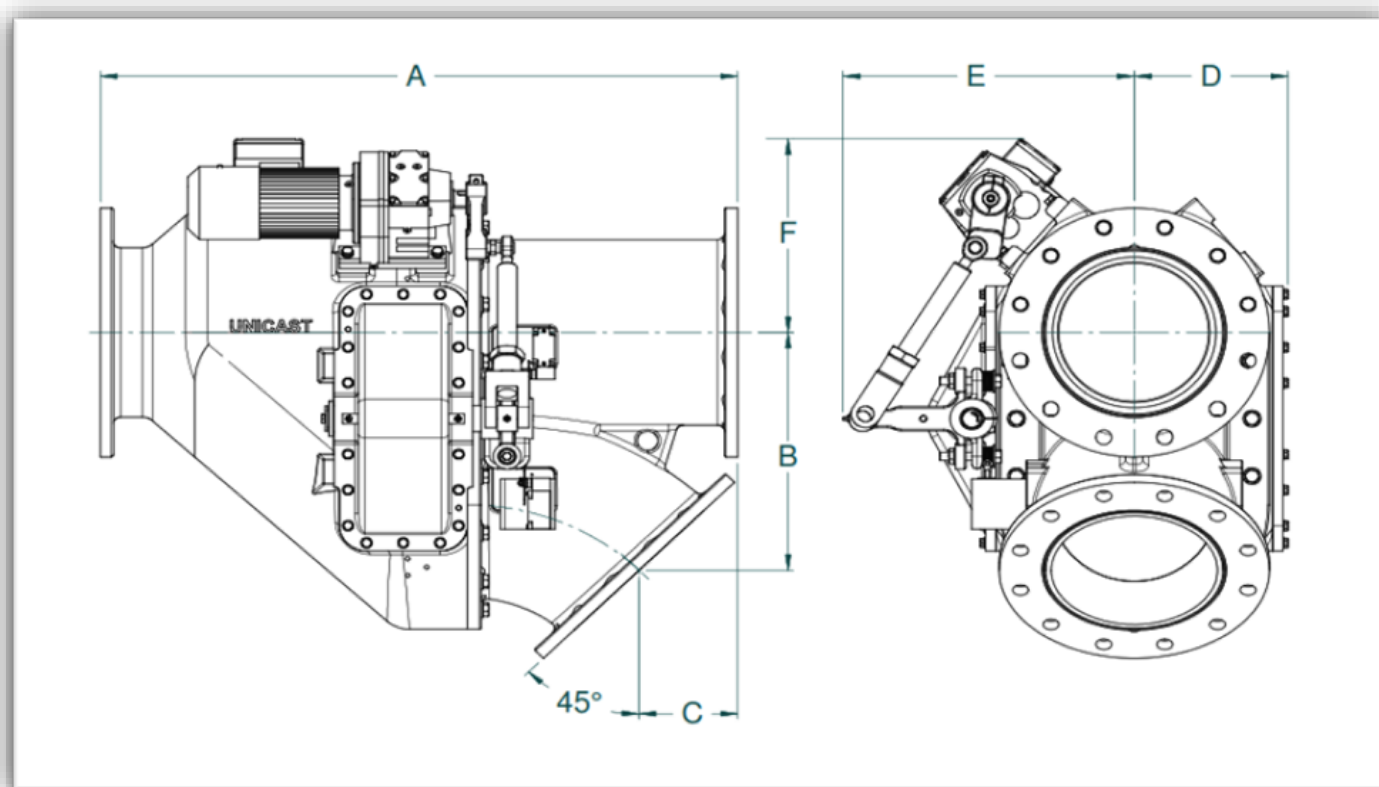

| PART NUMBER | SIZE | A | B | C | D | E | F | WEIGHT |
|-------------|-------|--------|--------|-------|---------|---------|---------|----------|
| U6408 | 8" | 36.00" | 13.70" | 5.25" | 7.57" | 17.00" | 13.70" | 586 Lbs |
| | 203mm | 914mm | 348mm | 134mm | 192.4mm | 431.5mm | 374.9mm | 266 Kg |
| U6410 | 10" | 40.00" | 17.00" | 7.13" | 9.12" | 19.00" | 14.00" | 820 Lbs |
| | 254mm | 1046mm | 432mm | 181mm | 231.6mm | 482.6 | 357mm | 372 Kg |
| U6412 | 12" | 46.00" | 18.62" | 7.00" | 11.08" | 20.95" | 15.18" | 1193 Lbs |
| | 305mm | 1168mm | 473mm | 178mm | 281.4mm | 535.2mm | 385.5mm | 541 Kg |
| U6414 | 14" | 61" | 21.81" | 9.00" | 11.84" | 24.57" | 17.38" | 2088 Lbs |
| | 356mm | 1549mm | 554mm | 229mm | 300.8mm | 624.2mm | 441.4mm | 947 Kg |
| U6416 | 16" | 62.50" | 24.25" | 8.54" | 12.8" | 25.95" | 20.31" | 2328 Lbs |
| | 406mm | 1588mm | 616mm | 217mm | 325mm | 659mm | 516mm | 1056 Kg |
| U6402 | 20" | 60.50" | 27.04" | 5.41" | 15.75" | 31.14" | 21.42" | 2893 Lbs |
| | 508mm | 1537mm | 687mm | 137mm | 400mm | 792mm | 544mm | 1312 Kg |
| U6400 | 24" | 70.00" | 31.65" | 6.25" | 18.00" | 33.81" | 21.65" | 4321 Lbs |
| | 610mm | 1778mm | 804mm | 159mm | 457mm | 859mm | 550mm | 1960 Kg |